

EP12P SERIE / SERIES

Sensore magnetico filettato M12x1
Threaded magnetic sensor M12x1

Corpo sensore in nylon vetro autoestinguente
 Uninflammable nylon glass body sensor



Collegamento <i>Connection</i>	CORPO / <i>BODY</i>		CONTATTO / <i>CONTACT</i>		
	Corpo tipo <i>Body type</i>	Colore <i>Colour</i>	Tensione <i>Voltage</i> V	Potenza <i>Power</i> W	Corrente <i>Current</i> A=W/V
NO 	EP12 PA	nero <i>black</i>	250	50	1 max
			250	100	3 max
NC 	EP12 PC	nero <i>black</i>	250	60	3 max
SCAMBIO EXC. 	EP12 PS	nero <i>black</i>	250	60	3 max
BISTABILE BISTABLE 	EP12 PB	nero <i>black</i>	250	100	3 max

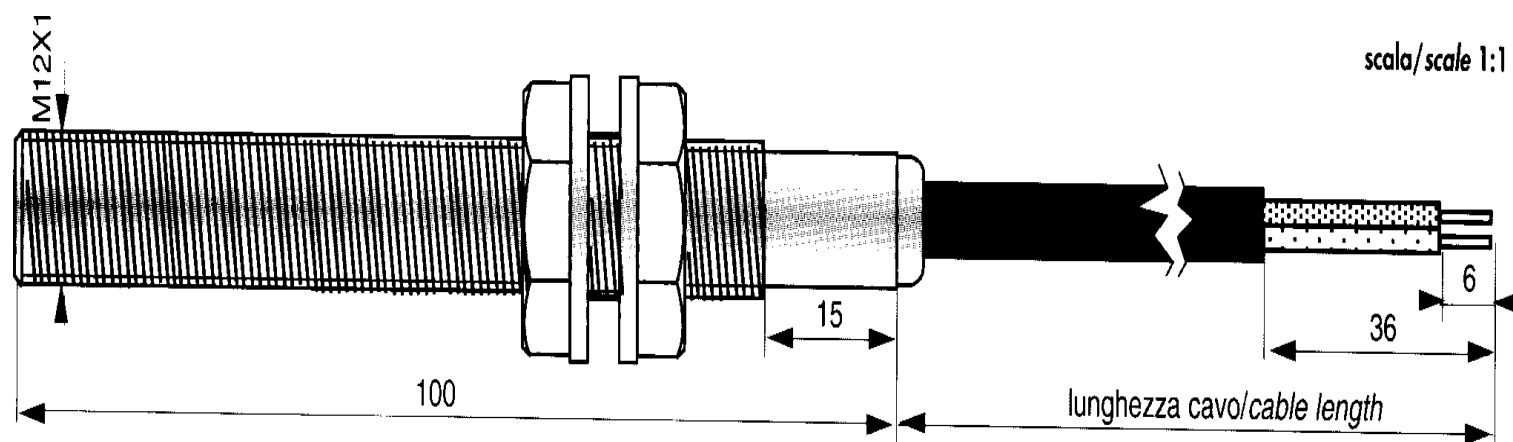

Come ordinare / *How to order*

EP12P A 200

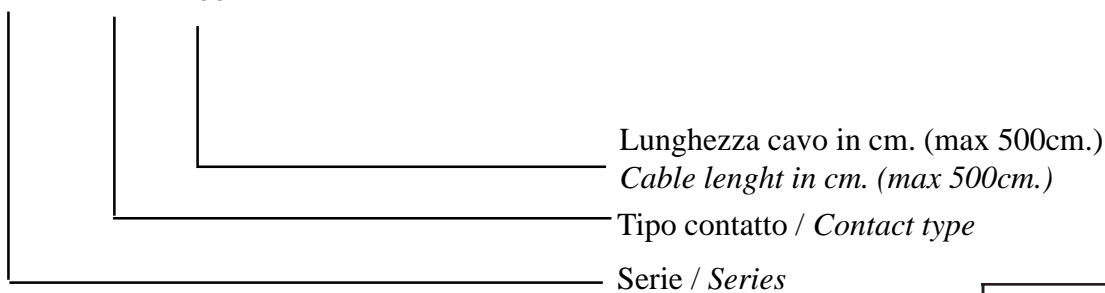

Caratteristiche tecniche <i>Technical features</i>	
Vite meccanica <i>Mechanical screw</i>	100.000.000
Frequenza di manovra <i>Operation frequency</i>	250 imp. / sec.
Ripetibilità <i>Accuracy</i>	0.1 mm
Resistenza agli urti <i>Impact resistance</i>	50 gr.
Resistenza alle vibrazioni <i>Vibration resistance</i>	35 gr.
Temperatura di esercizio <i>Working temperature</i>	-20 + 60

Electronica Due srl

Viale Italia 12 - 20094 Corsico (MILANO) Tel. +39.02.4487011 Fax +39.02.44870144
 www.elettronicadue.it e-mail : info@elettronicadue.it